



Authorized Value Added Reseller

CLEARCELL
POWER

Electric Load-Following Capability of the PureCell[®] Model 400 Fuel Cell System

A Doosan Fuel Cell America White Paper

Introduction

Electric load following can reduce energy expenses and increase the energy efficiency of a building by matching on site demand to available power. Doosan Fuel Cell America has been achieving groundbreaking success in energy efficiency for over 50 years. The latest stationary fuel cell system, the PureCell® System Model 400, has proven load-following capability to manage utility import from and export to the grid. In comparison to other fuel cells and intermittent renewable sources such as solar and wind, users of the PureCell system experience the advantages of higher efficiency and lower life-cycle costs while generating only the electricity that they require.

Electric Load Following Capability

The PureCell Model 400 system is capable of electric load following – an operating scheme that automatically adjusts the electrical output of the fuel cell to match the electrical demand of a facility. Key features that enable load following include:

- Fast transient response:
 - 10 kW/sec up transient
 - 20 kW/sec down transient
- Power output range between 10 kW and 400 kW when operating in parallel with the utility
- High part-load electrical efficiency
- Embedded control logic to automatically adjust power output to match an electrical load

In practice, load following is achieved by monitoring the power being drawn from the utility and adjusting the fuel cell output to minimize this utility import power, thereby matching the fuel cell output to the facility load demand. This is typically accomplished using a Watt transducer installed at the main utility feed that sends a 4-20 mA output signal wired directly into the PureCell system's on-board controller, as shown in Figure 1.

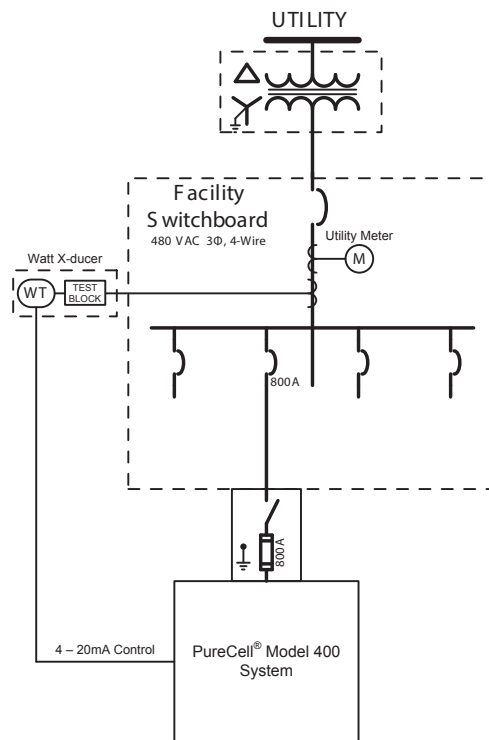

Figure 1. Electrical Schematic Showing Watt Transducer and Fuel Cell

The fuel cell’s load-following control system requires a set-point for the targeted minimum amount of utility power import desired. This set-point is known as the “minimum power import” setting. For installations not allowed to export to the utility grid, this minimum power import setting acts as a buffer to ensure that dynamic load conditions do not result in a power export condition. For sites that can take advantage of net metering, and are thus allowed to export to the utility grid, the minimum power import setting can be set to zero, and the fuel cell will match the building load.

Example: Preventing Power Export to the Utility

Figure 2 shows actual field data for a PureCell system installation that employs electric load following. In this example, the load-following controls are required to prevent power export to the utility grid, which would otherwise cause the utility to disconnect the fuel cell from its system (causing the fuel cell to operate in idle mode). The minimum power import setting at this site is 100 kW due to the relatively large step loads that are present in this industrial facility. As can be seen, the electric load of the building exceeds the fuel cell capacity of

400 kW during the week, allowing the fuel cell to operate at 100% power. On the weekends, however, the building load drops well below the fuel cell capacity, and the load-following controls take over, automatically reducing the fuel cell output to maintain a minimum utility import of 100 kW.

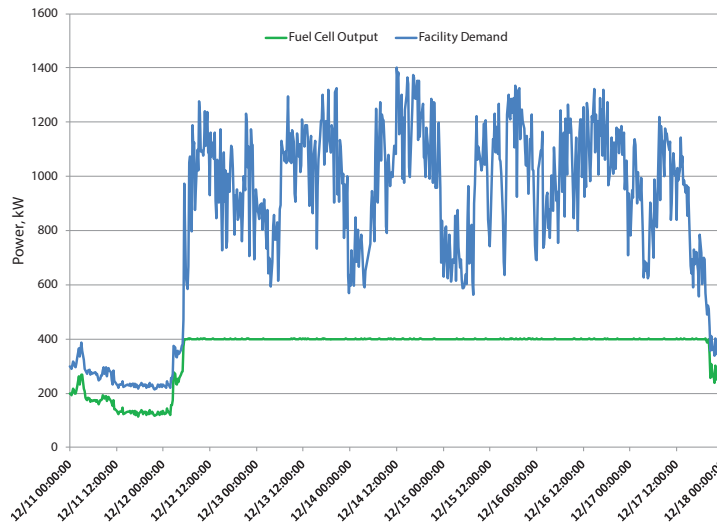

Figure 2. Load-Following Operating Data When Preventing Export to the Utility

The minimum power import setting is generally determined through an understanding of the building electrical loads, with specific focus on the largest loads that can be turned off quickly. If, for example, a large motor load such as a 50 kW electric chiller turns off, it will take the fuel cell 2.5 seconds to reduce its power output accordingly. In order to prevent power export to the utility, a 50 kW minimum import setting may be appropriate. In practice, the utility will typically allow a small amount of power export for a short period of time, which may allow for a lower minimum power import setting.

Example: Matching Building Load with Allowable Net Metering

Figure 3 shows actual field data for a PureCell system installation that matches the building load with a minimum power import setting of 0 kW. This installation is allowed to export power to the utility through the provisions of a net metering tariff. While the building owner could run the fuel cell at full power at all times and export all excess power to the utility, the price the utility pays for the exported power does not make it economically attractive to do so. Electric load-following controls are used to maximize fuel cell output and minimize utility import. Because exporting power for a short period of time (several seconds at most) is not a concern; there is no need to establish a buffer value, and the minimum power import is set for 0 kW.

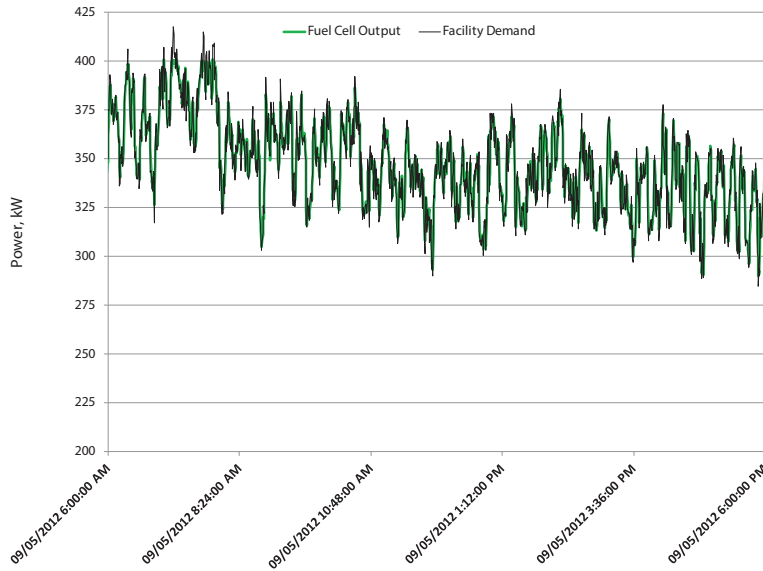

Figure 3. Load-Following Operating Data for Net Metering Site

High Part-Load Efficiency

The PureCell Model 400 system operates at reduced power output by reducing the natural gas input, thereby maintaining a high electrical efficiency. Figure 4 shows the system’s electrical efficiency and natural gas consumption at part-load operation. The system can operate reliably below 225 kW, but electrical efficiency decreases and continued operation at low power operation may not be economically advisable. Figure 4 also shows the available heat capacity of the fuel cell at part-power operation.

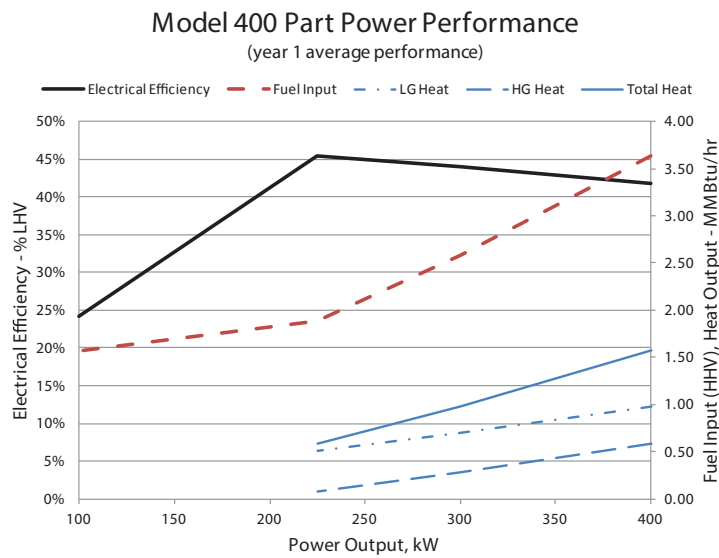

Figure 4. Electrical Efficiency and Natural Gas Consumption at Reduced Power Output

Conclusion

The PureCell system is not limited to baseload operation at full power output; it has the ability to follow a building's electrical load with high reliability and efficiency. Numerous fuel cell owners are benefiting today from the proven load-following capabilities of the PureCell system.

ClearCell Power, Inc
420 Lexington Avenue, Suite 1718
New York, NY 10070
646.661.5777
info@ClearCellPower.com

This document contains no technical information subject to U.S. Export Regulations.
Doosan Fuel Cell America, Inc.

